

Q1. Part of a bus route is along a high street.

The distance-time graph shows how far the bus travelled along the high street and how long it took.

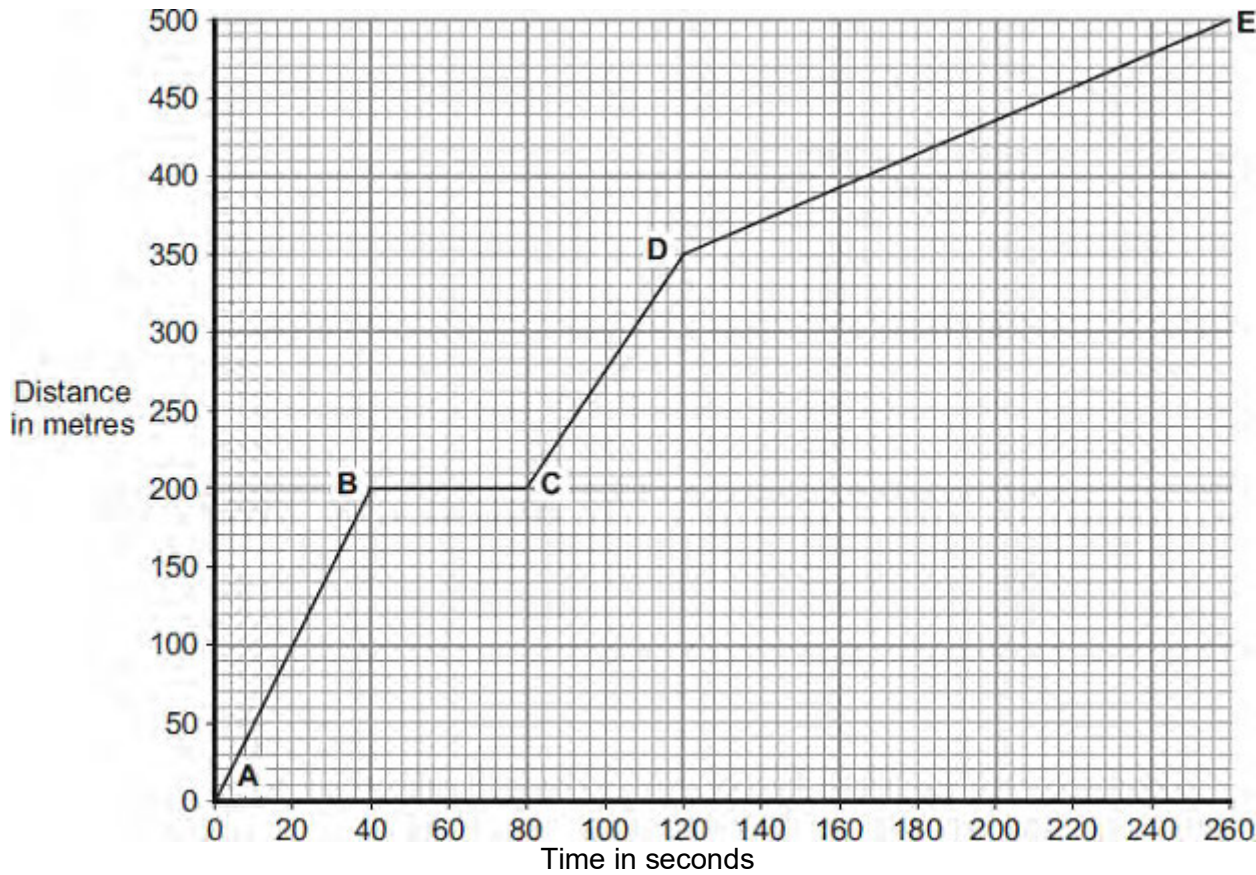

(a) Between which two points was the bus travelling the slowest?

Put a tick (✓) in the box next to your answer.

Points	Tick (✓)
A – B	
C – D	
D – E	

Give a reason for your answer.

.....

.....

(2)

- (b) The bus travels at 5 m/s between points **A** and **B**.
The bus and passengers have a total mass of 16 000 kg.

Use the equation in the box to calculate the momentum of the bus and passengers between points **A** and **B**.

momentum = mass x velocity

Show clearly how you work out your answer.

.....
.....

Momentum = kg m/s

(2)

- (c) A cyclist made the same journey along the high street.
The cyclist started at the same time as the bus and completed the journey in 220 seconds. The cyclist travelled the whole distance at a constant speed.

- (i) Draw a line on the graph to show the cyclist's journey.

(2)

- (ii) After how many seconds did the cyclist overtake the bus?

The cyclist overtook the bus after seconds.

(1)

(Total 7 marks)

Q2. The arrows in the diagram represent the horizontal forces acting on a motorbike at one moment in time.

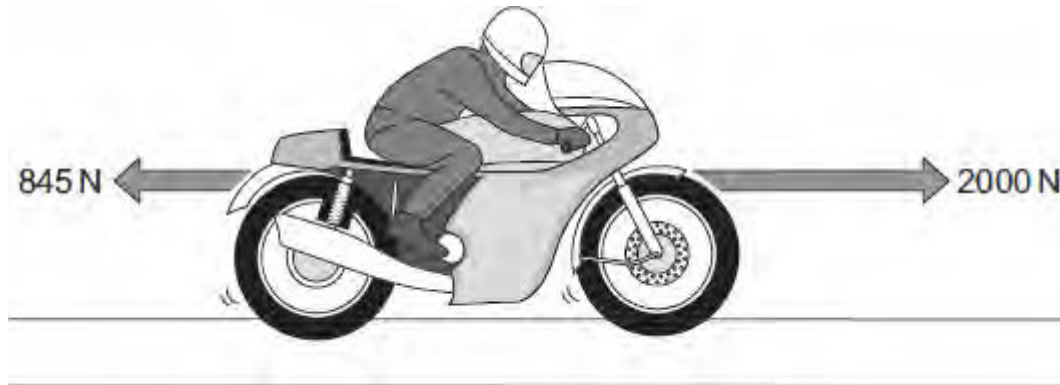

(a) The mass of the motorbike and rider is 275 kg.

Calculate the acceleration of the motorbike at this moment in time.

Show clearly how you work out your answer.

.....

.....

.....

.....

.....

Acceleration = m/s²

(3)

(b) A road safety organisation has investigated the causes of motorbike accidents.

The main aim of the investigation was to find out whether there was any evidence that young, inexperienced riders were more likely to be involved in an accident than older, experienced riders.

Data obtained by the organisation from a sample of 1800 police files involving motorbike accidents, is summarised in the table.

Size of motorbike engine	Percentage of all motorbikes sold	Total number in the sample of 1800 accident files
up to 125 cc	36	774
126 to 350 cc	7	126

351 to 500 cc	7	162
over 500 cc	50	738

Most of the motorbikes with engines up to 125 cc were ridden by young people. The motorbikes with engines over 500 cc were ridden by older, more experienced riders.

(i) In terms of the main aim of the investigation, is this data valid?

Draw a ring around your answer. **NO** **YES**

Explain the reason for your answer.

.....

.....

.....

.....

(2)

(ii) The organisation concluded that:

“Young, inexperienced riders are more likely to be involved in a motorbike accident than older, experienced riders”.

Explain how the data supports this conclusion.

.....

.....

.....

.....

(2)

(c) Of particular concern to motorbike riders is the design of steel crash barriers. Riders falling off and sliding at high speed into a steel support post are often seriously injured.

One way to reduce the risk of serious injury is to cover the post in a thick layer of high impact polyurethane foam.

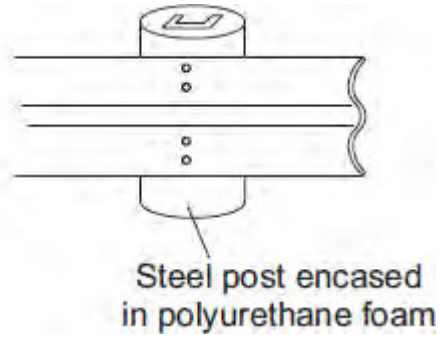
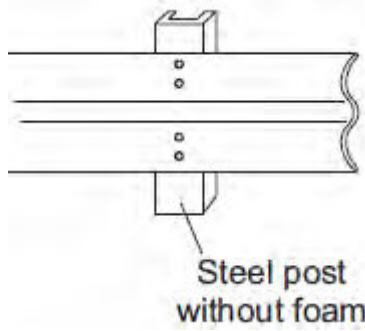

- (i) Use the ideas of momentum to explain how the layer of foam reduces the risk of serious injury to a motorbike rider sliding at high speed into the support post.

.....

.....

.....

.....

.....

(3)

- (ii) Crash barrier tests use dummies that collide at 17 m/s with the barrier. Each test costs about £12 000. New safety devices for crash barriers are tested many times to make sure that they will improve safety.

Do you think that the cost of developing the new safety devices is justified?

Draw a ring around your answer. **NO** **YES**

Give a reason for your answer.

.....

.....

(1)

(Total 11 marks)

Q3. The picture shows players in a cricket match.

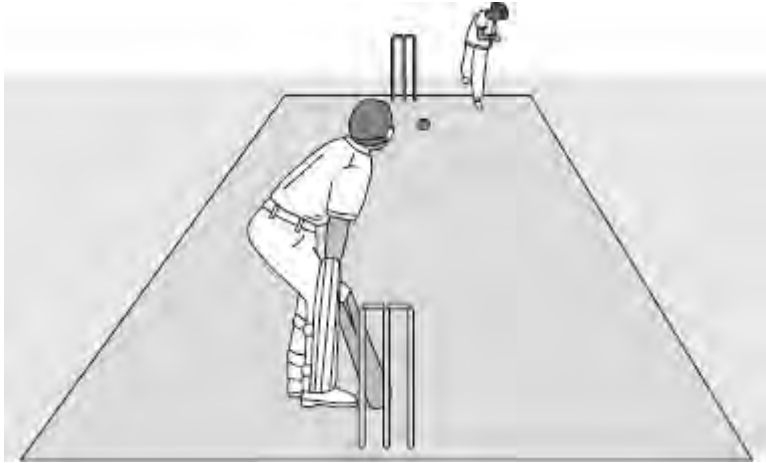

(a) A fast bowler bowls the ball at 35 m/s. The ball has a mass of 0.16 kg.

Use the equation in the box to calculate the kinetic energy of the cricket ball as it leaves the bowler's hand.

$\text{kinetic energy} = \frac{1}{2} \times \text{mass} \times \text{speed}^2$
--

Show clearly how you work out your answer.

.....

.....

.....

Kinetic energy = J

(2)

(b) When the ball reaches the batsman it is travelling at 30 m/s. The batsman strikes the ball which moves off at 30 m/s in the opposite direction.

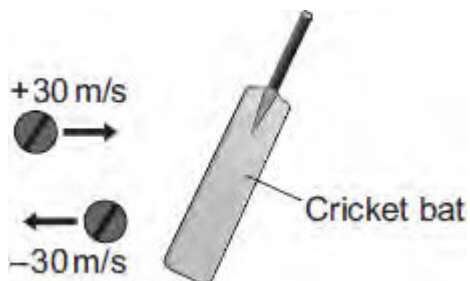

(i) Use the equation in the box to calculate the change in momentum of the ball.

$\text{momentum} = \text{mass} \times \text{velocity}$
--

Show clearly how you work out your answer.

.....
.....

Change in momentum = kg m/s

(2)

(ii) The ball is in contact with the bat for 0.001 s.

Use the equation in the box to calculate the force exerted by the bat on the ball.

$\text{force} = \frac{\text{change in momentum}}{\text{time taken for the change}}$

Show clearly how you work out your answer.

.....
.....

Force = N

(1)

(c) A fielder, as he catches a cricket ball, pulls his hands backwards.

Explain why this action reduces the force on his hands.

.....
.....
.....
.....
.....

(2)

(Total 7 marks)

Q4. (a) Complete the following sentence.

The momentum of a moving object has a magnitude, in kg m/s,
and a

(1)

(b) A car being driven at 9.0 m/s collides with the back of a stationary lorry.
The car slows down and stops in 0.20 seconds. The total mass of the car and driver
is 1200 kg.

Calculate the average force exerted by the lorry on the car during the collision.

Show clearly how you work out your answer.

.....
.....

Force = N

(2)

(c) Within 0.04 s of the car hitting the back of the lorry, the car driver's airbag inflates.
The airbag deflates when it is hit by the driver's head.



Use the idea of momentum to explain why the airbag reduces the risk of the driver
sustaining a serious head injury.

.....
.....
.....
.....
.....
.....

(3)

(Total 6 marks)

- Q5.(a)** The picture shows two teenagers riding identical skateboards.
The skateboards are moving at the same speed and the teenagers have the same mass.



Why do the teenagers **not** have the same momentum?

.....

(1)

- (b) One of the skateboards slows down and stops. The teenager then jumps off the skateboard, causing it to recoil and move in the opposite direction.

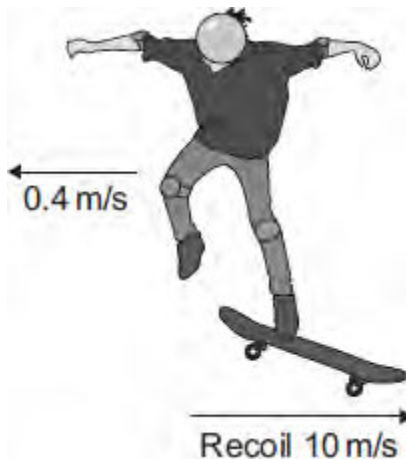

The momentum of the teenager and skateboard is conserved.

- (i) What is meant by 'momentum being conserved'?

.....

(1)

- (ii) The teenager, of mass 55 kg, jumps off the skateboard at 0.4 m/s causing the skateboard to recoil at 10 m/s.

Calculate the mass of the skateboard.

.....
.....
.....

Mass = kg

(3)

- (c) Once the skateboard starts to recoil, it soon slows down and its kinetic energy decreases.

Explain why.

.....
.....
.....
.....

(2)

(Total 7 marks)

Q6.(a) In any collision, the total momentum of the colliding objects is usually conserved.

(i) What is meant by the term 'momentum is conserved'?

.....

(1)

(ii) In a collision, momentum is **not always** conserved.

Why?

.....

(1)

(b) The diagram shows a car and a van, just before and just after the car collided with the van.

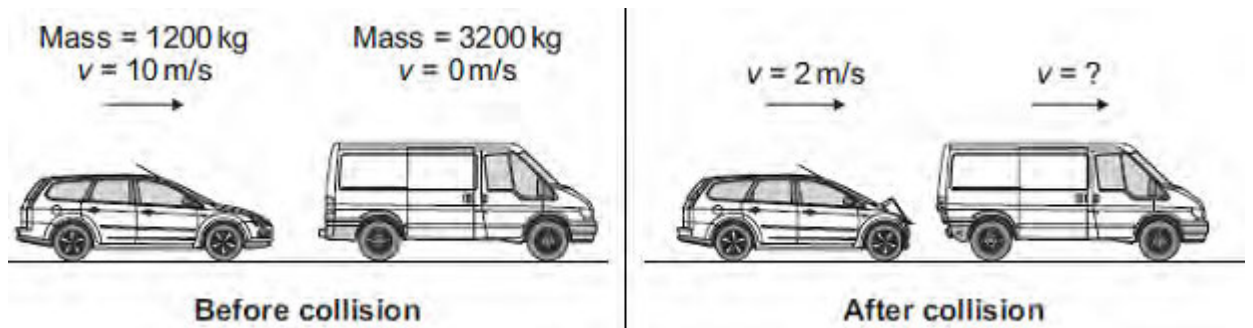

(i) Use the information in the diagram to calculate the **change** in the momentum of the car.

Show clearly how you work out your answer and give the unit.

.....

Change in momentum =

(3)

- (ii) Use the idea of conservation of momentum to calculate the velocity of the van when it is pushed forward by the collision.

Show clearly how you work out your answer.

.....
.....
.....

Velocity = m/s forward

(2)
(Total 7 marks)

Q7.A paintball gun is used to fire a small ball of paint, called a paintball, at a target.

The figure below shows someone just about to fire a paintball gun.

The paintball is inside the gun.



(a) What is the momentum of the paintball before the gun is fired?

.....

Give a reason for your answer.

.....

.....

(2)

(b) The gun fires the paintball forwards at a velocity of 90 m / s.

The paintball has a mass of 0.0030 kg.

Calculate the momentum of the paintball just after the gun is fired.

.....

.....

.....

Momentum = kg m / s

(2)

(c) The momentum of the gun and paintball is conserved.

Use the correct answer from the box to complete the sentence.

equal to	greater than	less than
-----------------	---------------------	------------------

The total momentum of the gun and paintball just after the gun is fired
will be the total momentum of the gun and
paintball
before the gun is fired.

(1)
(Total 5 marks)

Q8.The figure below shows a skateboarder jumping forwards off his skateboard.

The skateboard is stationary at the moment the skateboarder jumps.



(a) The skateboard moves backwards as the skateboarder jumps forwards.

Explain, using the idea of momentum, why the skateboard moves backwards.

.....
.....
.....
.....
.....
.....
.....
.....
.....

(3)

(b) The mass of the skateboard is 1.8 kg and the mass of the skateboarder is 42 kg.

Calculate the velocity at which the skateboard moves backwards if the skateboarder jumps forwards at a velocity of 0.3 m / s.

.....
.....
.....
.....
.....

.....

Velocity of skateboard = m / s

(3)
(Total 6 marks)